

## Dome Loaded Manifold NFPA



### General Specifications:

The Manifold shall be a fully automatic type and shall switch from "Bank in Use" to "Reserve Bank" without fluctuation in the final line pressure.

After the switchover, the "Reserve Bank" shall then become the "Bank in Use" and the "Bank in Use" shall become the "Reserve Bank." The control panel includes a line gauge, two bank gauges and incorporates six LED's: two green for "Bank in Use," two yellow for "Bank Ready" and two red for "Bank Empty" on the front of the cabinet. The manifold consists of two bank regulators (dome –bias) used to reduce the cylinder pressure to the two line regulators which in turn controls the final line pressure. The manifold has an intermediate and line relief valve that is internally connected to a common vent port, terminating into a 1/2" FNPT pipe.

The unit shall be compact, measuring 19" high x 17" wide x 9" deep.

#### NOTES

- The manifold shall be equipped with a 3/4" outlet shutoff valve. The valve comes complete with a 3/4" type "K" 6-3/4" [172mm] long pipe extensions and 1/8" port for an optional pressure switch.
- The header bars shall be equipped with high pressure shutoff valves outside the cabinet to allow for emergency isolation of the header bars. The header bar shall incorporate integral check valves for each station.
- The manifold is equipped with pressure transducers, which sends information to the main circuit board for operation of the fail-safe relay which transmits a remote signal to the master alarm or buzzer.
- The header bar mounting brackets are only supplied with more than 10 cylinders, for a staggered header bar, and more than 4 cylinders for a straight header bar.
- The Manifold cabinet has a NEMA-1 rating for general purpose use.
- Optional heaters are available for Nitrous Oxide and Carbon Dioxide manifolds.
- **The flow capacity of a nitrous oxide and carbon dioxide manifold depends upon the environmental conditions at the installation site and the number of cylinders in service. Installing them in a location that exposes it to an ambient temperature below 32°F (0°C) is not recommended.**
- The manifold shall be installed in accordance with the requirements stated by NFPA 99, CGA, and all applicable local codes. Amico recommends the control cabinet be located at an installation site protected from rain, snow and direct sunlight.
- CGA gas specific header bar with integral check valves and cylinder pigtail assemblies (to be ordered separately)

#### FLOW CAPACITY

Oxygen, Medical Air, Nitrous Oxide and Carbon Dioxide:

4,500 SCFH [2,123 L/min]

Nitrogen and Instrument Air:

6,000 SCFH [2,831 L/min]

### Features:

- Fully automatic with dual line regulators
- Input power 110 VAC to 240 VAC, 50 to 60 HZ
- Digital display noticeable even in poorest of lighting conditions
- 3/4" isolation valve for supply line
- Includes wall mounting bracket
- Removable cabinet enclosure made easy for easy installation and service
- Manifold complies with NFPA 99

# Technical Specifications

Inch  
[mm]

**Figure 1: Standard Set-up**

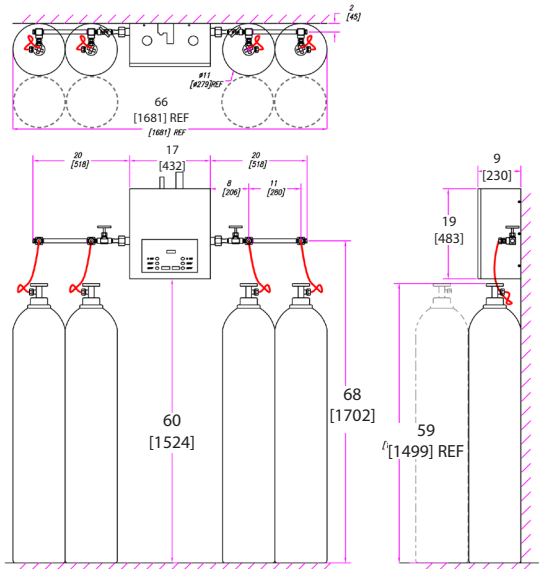

Standard 2x2 Dome Loaded Manifold with Straight Header Bars Layout

**Figure 2: Optional Set-up**

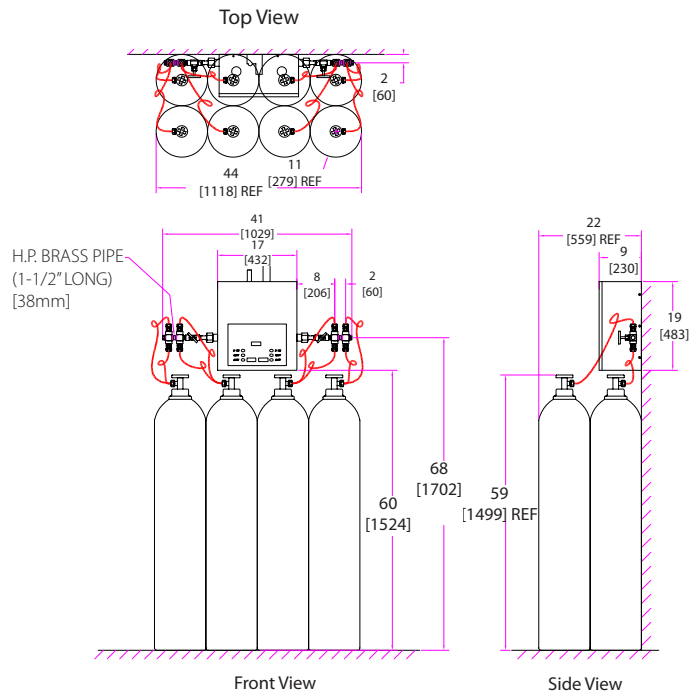

## Standard Setup Overall Length

No. of Cylinders	Overall Length
2	42 [1067]
4	42 [1067]
6	64 [1626]
8	64 [1626]
10	86 [2184]
12	86 [2184]
14	108 [2743]
16	108 [2743]
18	130 [3302]
20	130 [3302]

# Model Numbers

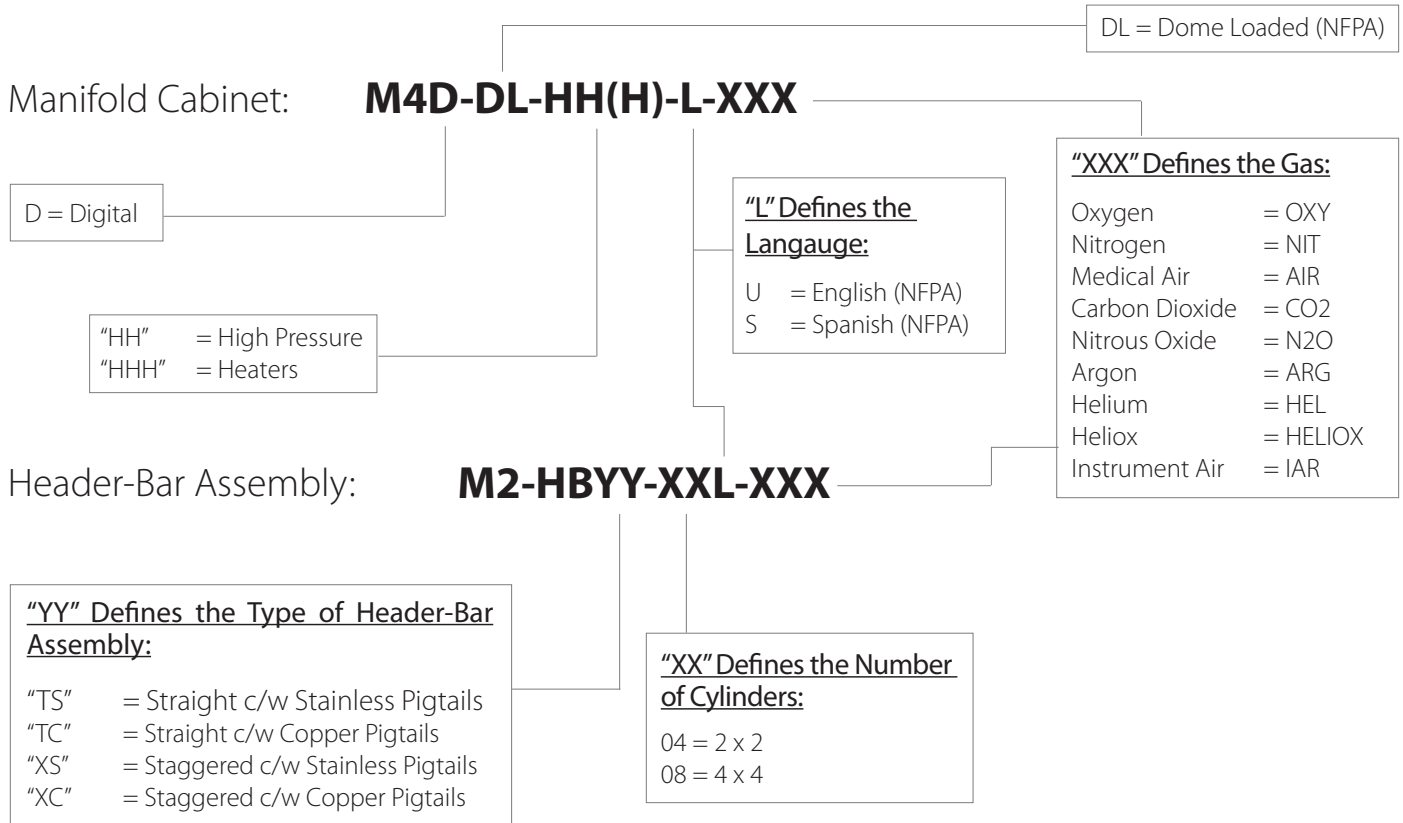

Wall Bracket for Header-Bar Assembly: **M-X-HB-WLBRKIT**

Distributed By: